

# ANSI/SDI A250.6

Revised October 2024

## Recommended Practice for Hardware Reinforcing on Standard Steel Doors & Frames

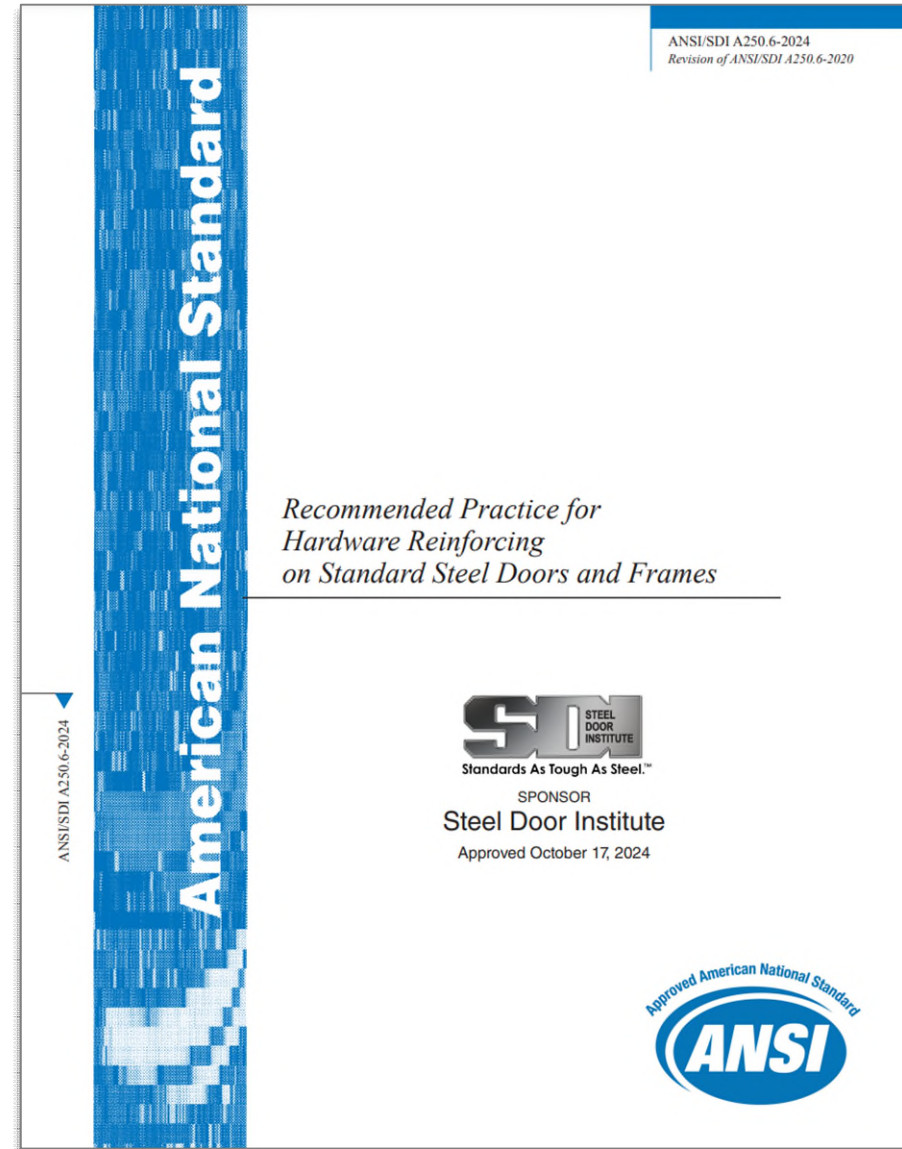

# ANSI/SDI A250.6 - 2024

---

- This standard serves as a guide to door and frame reinforcement, field preparation, and the installation of door hardware
- This standard should be referenced by hollow metal door installers to ensure doors are properly installed
- Doors with properly reinforced and installed hardware will function better and last longer than those without

# Description of A250.6

---

This standard provides installers of steel doors and frames with:

- 1 Practical information regarding accepted design methods for steel door hardware
- 2 Recommended practices for proper field preparation for builders' hardware
- 3 A variety of reinforcing methods produced by unique manufacturing processes
- 4 Information for doors and frames manufactured in accordance with **ANSI/SDI A250.8**

# A250.6 Overview

- For a screw to effectively secure the hardware it must have three threads within the door (see *Figure 2*), but a standard 18-gauge door is not quite thick enough for two threads
- These doors and frames require reinforcements or extrusions so three threads are within the door
- Failure to do so can cause the hardware to sag or possibly pull out from the door

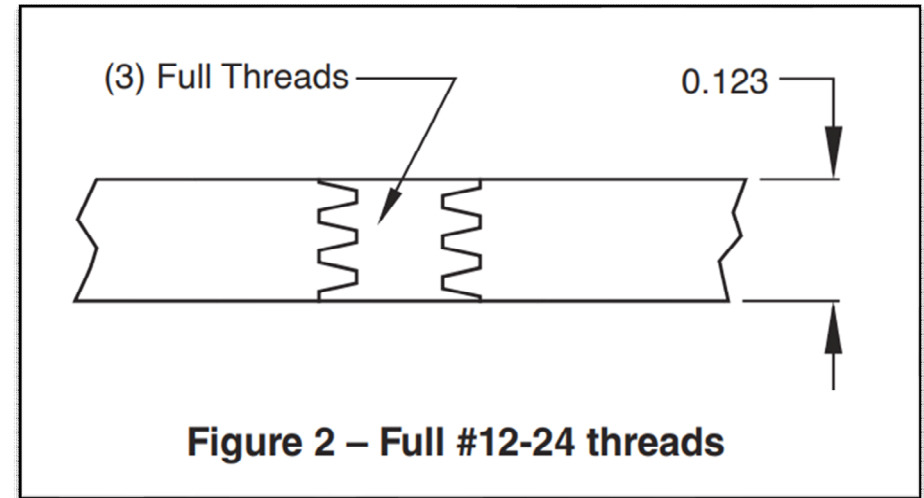

# A250.6 Overview

---

- Among other things, **A250.6** covers the reinforcement and extrusion of doors and frames
- In *Figure 1*, reinforcements are when a plate, channel or angle is attached to the door or frame to ensure the screws are properly secured

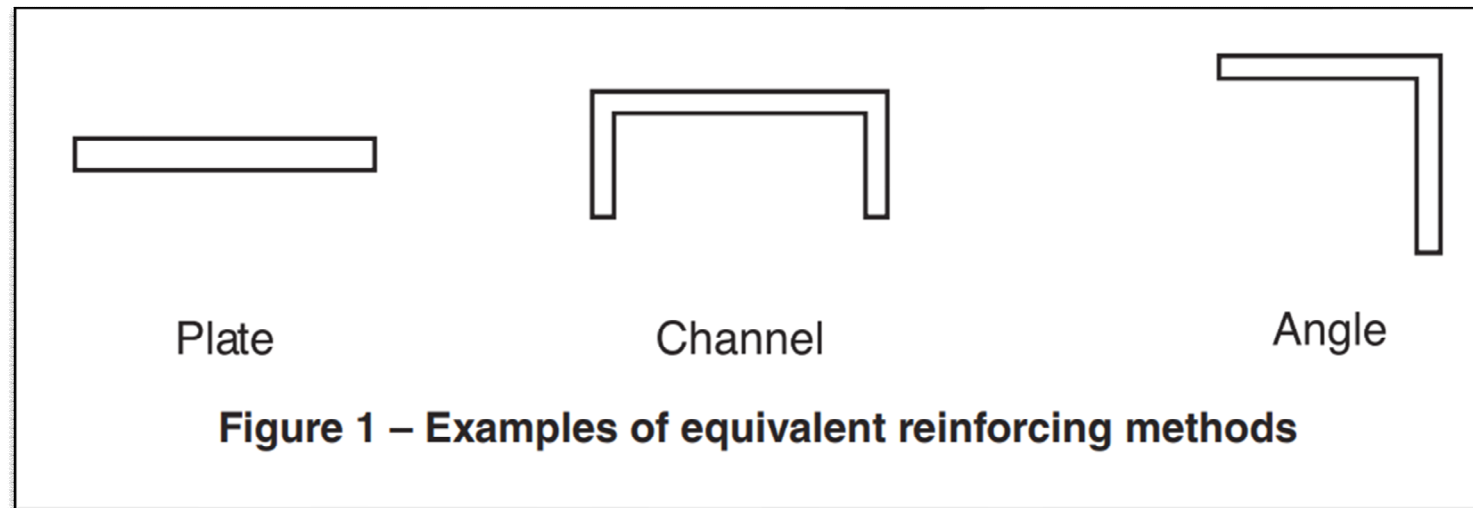

# A250.6 Overview

- Another method of properly securing screws is extrusion (see *Figure 3*), where a hole is punched in the door or frame and an extrusion tool is pressed into the hole
- This causes that part of the metal door to expand, making it wide enough for three screw threads

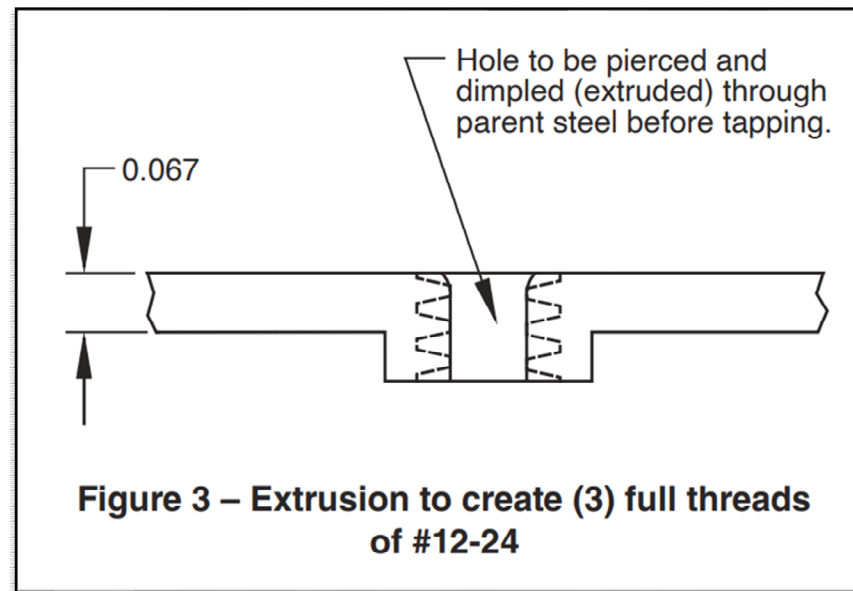

# A250.6 Overview

- *Table 1* shows the minimum reinforcing thicknesses for commonly installed hardware which an installer should reference before mounting hardware
- For example, if they were installing a mortise lock or deadbolt into an 18-gauge door, they would see that a 14-gauge reinforcement is suggested; therefore, the installer would need to reinforce it so the 18-gauge door is thick enough for three threads

**Table 1 – Minimum Hardware Reinforcing Thickness**

Hardware Item	Door		Frame	
	inches	MSG No. <sup>(6)</sup>	inches	MSG No. <sup>(6)</sup>
Mortise Hinge 1-3/8" Door <sup>(1)</sup>	0.093	12	0.093	12
Mortise Hinge 1-3/4" Door <sup>(1) (2)</sup>	0.123	10	0.123	10
Mortise Lock or Deadbolt <sup>(1)</sup>	0.067	14	0.067	14
Bored Lock or Deadbolt <sup>(1)</sup>	0.067	14	0.067	14

# A250.6 Overview

- The correct size of the pilot hole (see *Figure 4*) is also important to the security of the hinges
- It is easier to tap an oversize pilot hole than one of the correct size necessary for maximum strength
- Oversized holes (see *Figure 5*) will not ensure adequate product performance
- Also covered is through-bolting, sheet metal screws, and continuous hinges

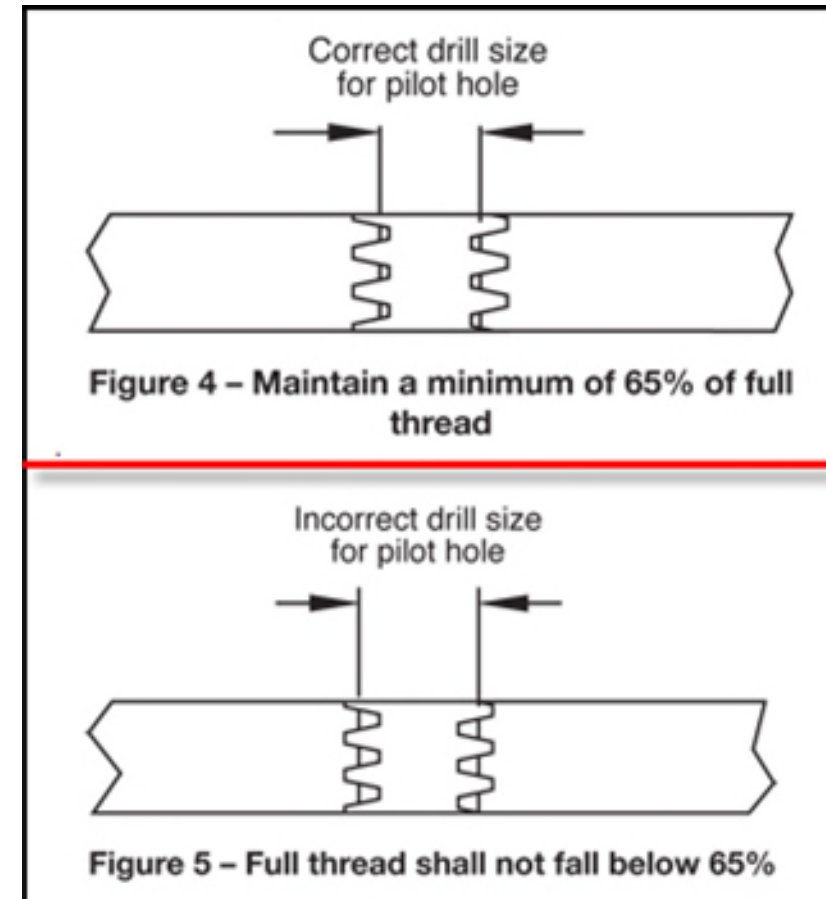



# A250.6 Overview

---

- It has been the experience of the Steel Door Institute that most failures of hardware attachments have been caused by improper field installation rather than insufficient reinforcement
- Manufacturing tolerances and dimensions may not always be consistent on machine and sheet metal screws when compared with different sources of supply
- Specification writers must be aware that proper installation methods must be followed on an equal basis with door and hardware construction requirements for a door to perform to its potential

# SDI Member Companies

