

American National Standard

*Recommended Practice for
Hardware Reinforcing
on Standard Steel Doors and Frames*



Standards As Tough As Steel.™

SPONSOR

Steel Door Institute

Approved October 17, 2024



This page left intentionally blank.

American National Standard

**Recommended Practice
for Hardware Reinforcing
on Standard Steel Doors and Frames**

Secretariat
Steel Door Institute

Approved October 17, 2024
American National Standards Institute, Inc.

This page left intentionally blank.

American National Standard

Approval of an American National Standard requires verification by ANSI that the requirements for due process, consensus, and other criteria for approval have been met by the standards developer.

Consensus is established when, in the judgement of the ANSI Board of Standards Review, substantial agreement has been reached by directly and materially affected interests. Substantial agreement means much more than a simple majority, but not necessarily unanimity. Consensus requires that all views and objections be considered, and that a concerted effort be made toward their resolution.

The use of American National Standards is completely voluntary; their existence does not in any respect preclude anyone, whether they have approved the standards or not, from manufacturing, marketing, purchasing, or using products, processes, or procedures not conforming to the standards.

The American National Standards Institute does not develop standards and will in no circumstances give any interpretation of any American National Standard. Moreover, no person shall have the right or authority to issue an interpretation of an American National Standard in the name of the American National Standards Institute. Requests for interpretations should be addressed to the secretariat or sponsor whose name appears on the title page of this standard.

CAUTION NOTICE: This American National Standard may be revised or withdrawn at any time. The procedures of the American National Standards Institute require that action be taken periodically to reaffirm, revise, or withdraw this standard. Purchasers of American National Standards may receive current information on all standards by calling or writing the American National Standards Institute.

Published by

Steel Door Institute
30200 Detroit Road, Cleveland, Ohio 44145-1967

Copyright © 2024 by Steel Door Institute
All rights reserved.

No part of this publication may be reproduced in any form, in an electronic retrieval system or otherwise, without prior written permission of the publisher.

Printed in the United States of America

ANSI/SDI A250.6-2024

This page left intentionally blank.

Contents

	Page
Foreword.....	ii
1 General	1
1.1 Purpose.....	1
1.2 Scope.....	1
1.3 Reinforcing Methods	1
2 Reference Documents.....	1
3 Recommended Reinforcing Thickness	1
4 Recommended Application of Hardware	3
4.1 Mortised Hardware.....	3
4.2 Field Drilling and Tapping	3
4.3 Thru-Bolting.....	3
4.4 Sheet Metal Screws.....	4
5 Continuous Hinges.....	4

Tables

1 Minimum Hardware Reinforcing Thickness.....	2
2 #10-24 thread	4
3 #12-24 thread	4
4 Tap drills and clearance drills for machine screws with American National Thread form	5

Figures

1 Examples of equivalent reinforcing methods.....	1
2 Full #12-24 threads.....	2
3 Extrusion to create (3) full threads of #12-24	2
4 Maintain a minimum of 65% of full thread	3
5 Full thread shall not fall below 65%	3
6 Proper thru-bolting.....	4
7 Improper thru-bolting	4

Appendices

A Conclusion.....	6
B Bibliography.....	7

Foreword (This Foreword is not part of American National Standard A250.6-2024)

The first edition of this standard was developed under the auspices of the Technical Committee of the Steel Door Institute and published in 1978 as SDI-107 Hardware on Steel Doors (Reinforcement – Application). In 1994, the word “standard” was added to the document’s title and the decision was made to promulgate SDI-107 as an American National Standard. A250.6 was officially approved by the American National Standards Institute on October 22, 1997. Substantive changes between SDI-107 and the revised and redesignated A250.6-1997 Hardware on Standard Steel Doors (Reinforcement – Application) include the addition of metric equivalents, revised tap and drill sizes to eliminate those that are not recommended, and a better definition for “factory mortise.”

In 2001, the TC-1 Committee of the Accredited Standards Committee A250 initiated the 5-year review process, and changed the title of A250.6 to Recommended Practice for Hardware Reinforcing on Standard Steel Doors and Frames to more accurately define the content of the standard. In addition, this revision includes the following substantive changes: Addition of Appendices A and B, both informative; discontinuation of the use of “gauge” in favor of decimal equivalents; addition of information relating to continuous hinges; redefinition of the scope to exclude “architecturally specified or specialized conditions.”

In 2015, A250.6 was revised due to the following updates: Figure 1 – title changed from “Rigidity of angle or channel versus plate” to “Examples of equivalent reinforcing methods”; Figure 6 – Sex-bolted changed to “proper thru-bolting. Description changed from sex nut full door thickness” to “Grommet nut of sex bolt or barrel nut spans full door thickness”; Figure 7 – “Grommet nut does not span full door thickness changed to “Grommet nut of sex bolt or barrel nut does not span full door thickness”; Section 1.3.1 – “equal strength” was changed to “equal strength, pull-out strength”

In 2020 the standard was balloted and approved as a revision, due to updates in the “Reference documents” section.

In 2024 the standard was balloted and approved as a revision, due to updates in the “Reference documents” section and the removal of metric/metric equivalents throughout.

Suggestions for improvement gained in the use of this standard will be welcome, and should be sent to the Steel Door Institute, 30200 Detroit Road, Cleveland, Ohio 44145-1967.

The organizations of the Accredited Standards Committee A250 that have approved this standard are as follows:

Builders Hardware Manufacturers Association
Canadian Steel Door Manufacturers Association
Rosa D. Cheney AIA
D.H. Pace
Door and Hardware Institute
Door Control Services
ESTM Services, LLC
GCI Consultants, LLC
HMMA/Division of NAAMM
Intertek
MasterSpec
Steel Door Institute
UL Solutions
Vetrotech / Saint Gobain

The Accredited Standards Committee A250 TC-1 developed this standard had the following personnel at the time of approval:

David Bill, Chairman
Claus Heide, Vice Chairman
J. Jeffery Wherry, Secretary

<i>Organization Represented</i>	<i>Name of Representative</i>
Ceco.....	Kurt Roeper
Curries.....	David Bill
D.H. Pace Company.....	Jerry Rice
DCI.....	Henry Ray
De La Fontaine Industries, Inc.	René Bouchard
Deansteel Manufacturing Company.....	Claus Heide
Hollow Metal Xpress.....	Adam Matusz
Mesker Door, Inc.	Mike Mehaffy
MPI.....	David McConnell
Pioneer.....	Kamal Sheikh
Premier.....	Jason Lisewski
Republic.....	Marilyn Latham
Steelcraft.....	Tim Weller
Stiles.....	Terry Fittje

This page left intentionally blank.

American National Standard

Recommended Practice for Hardware Reinforcing on Standard Steel Doors and Frames

1 General

1.1 Purpose

It is the intention of this publication to furnish users and prospective users of standard steel doors and frames with practical information regarding accepted design methods for reinforcing and recommended practices for proper field preparation for builders' hardware.

1.2 Scope

The information contained herein pertains to doors and frames manufactured in accordance with ANSI/SDI A250.8 *Specifications for Standard Steel Doors and Frames* published by the Steel Door Institute. It is not intended to reference architecturally specified or specialized situations beyond the scope of this document or documents herein.

1.3 Reinforcing Methods

This standard recognizes as equal a variety of reinforcing methods produced by unique manufacturing processes. These processes include forming options (see figure 1) or integral gussets or fillets on lighter gauge members to achieve strength and performance equal to heavier gauge members.

1.3.1 Where reinforcements require tapping for machine screw threads, an equivalent number

of threads may be rendered in a lighter gauge part with a pierced and dimpled ("extruded") hole as compared to a heavier gauge part manufactured with conventional processes. For example, equal thread depth can be achieved on a piece of 0.067" metal and on a flat plate of 0.123" metal (see figures 2 and 3). The extrusion process results in equal strength, pull-out strength, equivalent number of threads and a lighter weight than the parent metal or equivalent flat reinforcing plate.

2 Reference Documents

ANSI/SDI A250.4-2024 *Test Procedure and Acceptance Criteria for – Physical Endurance for Steel Doors, Frames and Frame Anchors*

ANSI/SDI A250.8-2023 *Specifications for Standard Steel Doors and Frames*

Machinery's Handbook

3 Recommended Reinforcing Thickness

The Manufacturer, based on individual construction methods and tooling capabilities, shall reinforce their product to ensure performance in accordance with ANSI/SDI A250.4. This reinforcing shall include (unless noted otherwise) reinforcing and tapped mounting holes for template hinges and ANSI defined locks

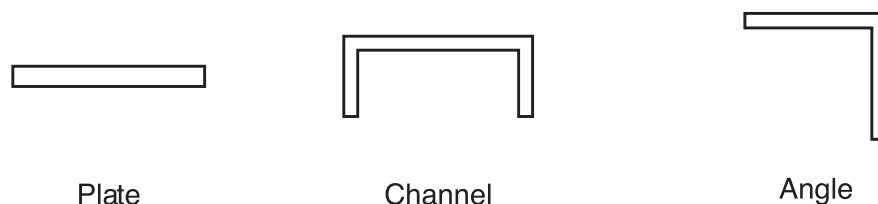

Figure 1 – Examples of equivalent reinforcing methods

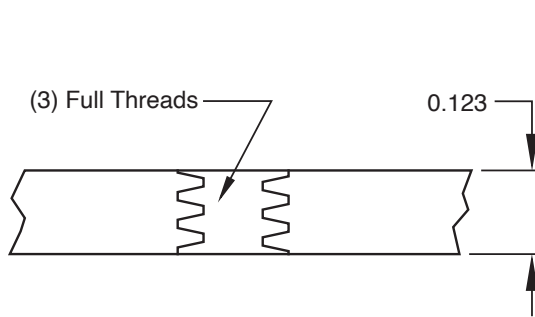

Figure 2 – Full #12-24 threads

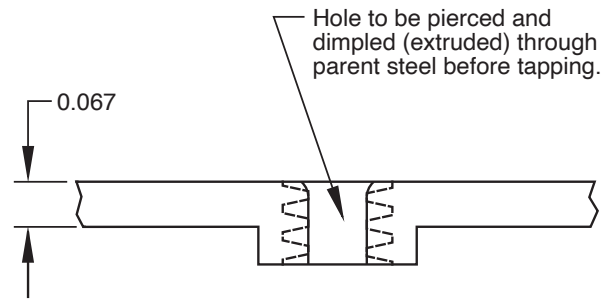

Figure 3 – Extrusion to create (3) full threads of #12-24

Table 1 – Minimum Hardware Reinforcing Thickness

Hardware Item	Door		Frame	
	inches	MSG No. ⁽⁶⁾	inches	MSG No. ⁽⁶⁾
Mortise Hinge 1-3/8" Door ⁽¹⁾	0.093	12	0.093	12
Mortise Hinge 1-3/4" Door ^{(1) (2)}	0.123	10	0.123	10
Mortise Lock or Deadbolt ⁽¹⁾	0.067	14	0.067	14
Bored Lock or Deadbolt ⁽¹⁾	0.067	14	0.067	14
Flush Bolt Front ⁽¹⁾	0.067	14	0.067	14
Surface Bolt ⁽³⁾	0.067	14	0.067	14
Surface Applied Closer ⁽⁴⁾	0.067	14	0.067	14
Hold Open Arm ⁽³⁾	0.067	14	0.067	14
Pull Plates and Bar ⁽³⁾	0.053	16	0.053	16
Surface Exit Device ⁽³⁾	0.067	14	0.067	14
Floor Checking Hinge	0.167	7	0.167	7
Pivot Hinge	0.167	7	0.167	7
Continuous Hinges ⁽⁵⁾	Per Specification		Per Specification	
Kick / Push Plate	Per Specification		Per Specification	

Note: The minimum steel thickness for each specific gauge is derived from the published figures of UL Solutions. Thickness listed is in addition to door/frame specified thickness.

⁽¹⁾ Thinner steel may be employed as long as tapped holes used for mounting the hardware are extruded to produce an equivalent number of threads.

⁽²⁾ If reinforcing is angular or channel shaped, 0.093" is permitted.

⁽³⁾ When reinforcing is omitted, thru-bolting via the use of spacers or sex-bolts is required.

⁽⁴⁾ Reinforcement shall occur on both sides.

⁽⁵⁾ Refer to section 6.

⁽⁶⁾ MSG No. to be used for reference purposes only.

as specified. Additional reinforcing for surface applied hardware shall be built into the door at the factory when specified.

As a guide to specification writers, table 1 shows the minimum thickness of steel to be used for hardware reinforcing as endorsed by ANSI/SDI A250.8.

4 Recommended Application of Hardware

The hardware installer shall carefully follow the hinge manufacturer's instructions for fastener preparations.

4.1 Mortised Hardware

Standardized and ANSI defined preparations are made at the factory to allow installation of mortise hardware such as hinges and locks. Holes shall be made to precise diameters and accurately tapped to ensure maximum thread engagement and holding strength. Cutouts shall be pierced to surround the mortised hardware item to close tolerances on three or all four sides. The hardware shall be installed using only the proper screws as furnished with or specifically recommended for each device.

NOTE: The installer must exercise caution upon initial insertion of screws to prevent cross threading, especially with the smaller diameter screws.

4.2 Field Drilling and Tapping

Doors and frames shall be prepared by the installer in the field for surface applied hardware, such as surface closers or holders, track type concealed closers or holders, pulls, exit device cases, or vertical rod latches. In addition, some hardware such as anchor hinges, thrust pivots, pivot reinforced hinges or floor mounted pivots must be field prepared due to design variations

or to provide adjustment that can only be provided at time of installation. The installer shall use a template provided with the device or the device itself to locate hole spacing.

4.2.1 A suitably sized punch shall be used to locate the drilling for pilot holes to prevent drill creeping, off-center holes and improper screw alignment.

IMPORTANT NOTE: Use only the correct size drill for pilot holes, as recommended by *Machinery's Handbook* (see table 4). Larger holes will decrease screw holding power causing the screw to be pulled from the reinforcing under normal stresses (see figures 4 and 5).

Tables 2 and 3 illustrate the effect of variances in pilot hole sizes on thread holding power.

4.2.2 The installer shall assure that tapped holes have 75% of full thread (considered a normal condition). This percentage shall not fall below 65% to be considered adequate for proper hardware fastenings. Drills shall be positioned so the bit enters the reinforced area in perpendicular position as holes formed at angles will not permit proper seating of the screw head. After the proper pilot holes are drilled, proceed with the tapping operation. The tap shall match the thread size of the screws provided and the tap shall be held perpendicular to the surface.

4.3 Thru-Bolting

Where reinforcing has not been specified or provided for other than mortised hardware, attachment shall be accomplished by thru-bolting. The hardware manufacturer's instruction sheets shall be closely followed for recommended procedures. Where thru-bolting is required on hollow metal doors, spacers or sex-bolts shall

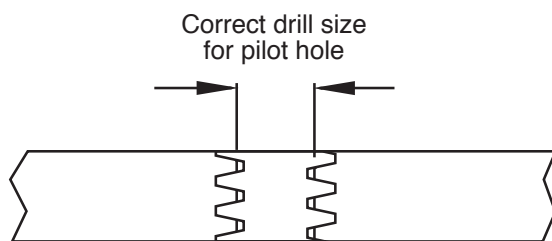

Figure 4 – Maintain a minimum of 65% of full thread

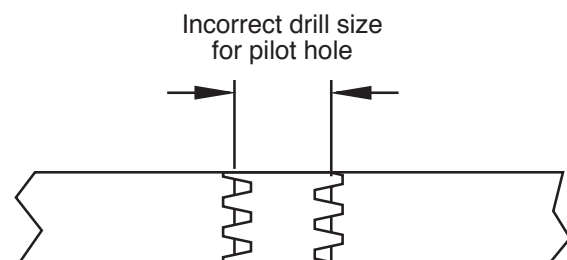

Figure 5 – Full thread shall not fall below 65%

Table 2 – #10-24 thread

Drill Size	Drill Diameter	% Full Thread
#23	0.154"	66%
#24	0.152"	70%
#25	0.149"	75%
#26	0.147"	79%
#27	0.144"	85%
<i>Machinery's Handbook</i> recommendation in BOLD		

be used to prevent collapsing of face sheets as illustrated in figures 6 and 7.

NOTE: The most popular thru-bolting applications are door closers, exit devices, overhead holders, pulls and bar sets.

4.4 Sheet Metal Screws

Sheet metal screws are normally used to attach accessory hardware such as kickplates, mail slots, room numbers, identification signs, and in many instances, push or pull plates. These areas are not reinforced beyond the thickness of the face sheets. Properly sized holes and correct sheet metal screws as provided with the hardware item or as specified in the mounting instructions shall be used for hardware attachment.

4.4.1 The best performance is achieved when the space between the threads is equal to or greater than the thickness of the face sheets.

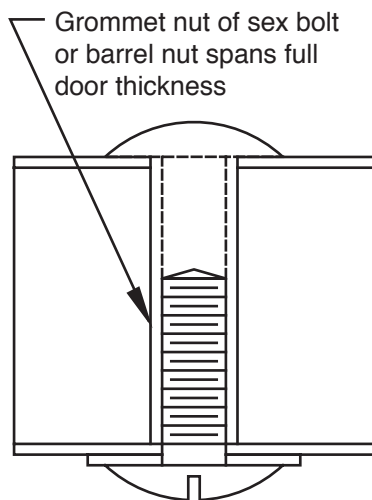

Figure 6 – Proper thru-bolting

Table 3 – #12-24 thread

Drill Size	Drill Diameter	% Full Thread
#15	0.180"	66%
#16	0.177"	70%
#17	0.173"	75%
<i>Machinery's Handbook</i> recommendation in BOLD		

5 Continuous Hinges

5.1 Standard preparation for continuous gear type or barrel type hinges shall not include any factory reinforcing, drilling and/or tapping in doors or frames. All mounting shall be prepared in the field by the hardware installer.

5.2 For continuous hinges that require reinforcing (either for fasteners, door weight, door size or frequency of use situations) reinforcing shall be indicated at the time of order.

5.2.1 Standard reinforcing shall be a 0.067" steel strip no less than 1-1/4" in width securely welded inside the hinge edge of doors and hinge jamb door rabbet of frames.

5.2.2 Optional reinforcing shall be a 0.067" steel strip no less than 1-1/4" in width securely welded inside the hinge jamb door side face of frames.

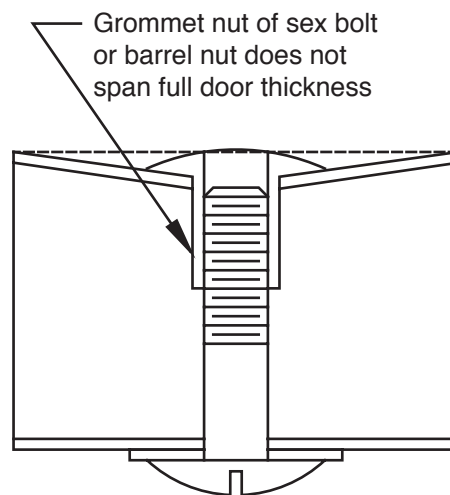

Figure 7 – Improper thru-bolting

**Table 4 – Tap drills and clearance drills for machine screws
with American National Thread form**

Size of Screw		No. of Threads per Inch	Tap Drills		Clearance Hole Drills			
No. or Diam.	Decimal Equiv.		Drill Size	Decimal Equiv.	Close Fit		Free Fit	
					Drill Size	Decimal Equiv.	Drill Size	Decimal Equiv.
0	.060	80	3/64	.0469	52	.0635	50	.0700
1	.073	64	53	.0595	48	.0760	46	.0810
		72	53	.0595				
2	.086	56	50	.0700	43	.0890	41	.0960
		64	50	.0700				
3	.099	48	47	.0785	37	.1040	35	.1100
		56	45	.0820				
4	.112	36*	44	.0860	32	.1160	30	.1285
		40	43	.0890				
		48	42	.0935				
5	.125	40	38	.1015	30	.1285	29	.1360
		44	37	.1040				
6	.138	32	36	.1065	27	.1440	25	.1495
		40	33	.1130				
8	.164	32	29	.1360	18	.1695	16	.1770
		36	29	.1360				
10	.190	24	25	.1495	9	.1960	7	.2010
		32	21	.1590				
12	.216	24	16	.1770	2	.2210	1	.2280
		28	14	.1820				
14	.242	20*	10	.1935	D	.2460	F	.2570
		24*	7	.2010				
1/4	.250	20	7	.2010	F	.2570	H	.2660
		28	3	.2130				
5/16	.3125	18	F	.2570	P	.3230	Q	.3320
		24	I	.2720				
3/8	.375	16	5/16	.3125	W	.3860	X	.3970
		24	Q	.3320				
7/16	.4375	14	U	.3680	29/64	.4531	15/32	.4687
		20	25/64	.3906				
1/2	.500	13	27/64	.4219	33/64	.5156	17/32	.5312
		20	29/64	.4531				

* Screws marked with asterisk (*) are not in the American Standard but are from the former ASME Standard.

Appendix A
(informative)

Conclusion

It has been the experience of the Steel Door Institute that most failures of hardware attachments have been caused by improper field installation rather than insufficient reinforcement. It is quite obvious that it is easier to tap an oversize pilot hole than to tap one of correct size necessary for maximum strength. Oversized holes will not ensure adequate product performance.

Manufacturing tolerances and dimensions may not always be consistent on machine and sheet metal screws when compared with different sources of supply.

The material used for the manufacture of screws is also a factor in the overall performance of the attachment. Stainless steel, for example, is a stronger fastener than aluminum or plain carbon steel. On installations where vibration or unusual frequency of operation is a factor, the use of thread locking inserts, liquids on threads, or binding heads should be considered.

Standard steel doors and builders hardware are made to provide many years of service and are very compatible. The specification writer and construction superintendent must be aware, however, that proper installation methods must be considered on an equal basis with door and hardware construction requirements to achieve this compatibility on the job.

Appendix B
(informative)

Bibliography

- HMMA 803 *Steel Tables*
- HMMA 830 *Hardware Selection for Hollow Metal Doors and Frames*
- HMMA 840 *Guide Specification for Installation and Storage of Hollow Metal Doors and Frames*
- SDI-117 *Manufacturing Tolerances for Standard Steel Doors and Frames*
- SDI-122 *Installation Troubleshooting Guide for Standard Steel Doors and Frames*
- SDI-134 *Glossary of Terms for Hollow Metal Doors and Frames*

AVAILABLE PUBLICATIONS

Specifications

- ANSI/SDI A250.6** Recommended Practice for Hardware Reinforcing on Standard Steel Doors and Frames
- ANSI/SDI A250.8** Specifications for Standard Steel Doors and Frames (SDI-100)
- ANSI/SDI A250.14** Hardware Preparation in Steel Doors and Steel Frames
- SDI-108** Recommended Selection & Usage Guide for Standard Steel Doors
- SDI-118** Basic Fire Door, Fire Door Frame, Transom/Sidelight Frame, and Window Frame Requirements
- SDI-128** Guidelines for Acoustical Performance of Standard Steel Doors and Frames
- SDI-129** Hinge and Strike Spacing
- SDI-133** Guideline for Specifying Steel Doors & Frames for Blast Resistance
- SDI-136** Guideline for Specifying Windstorm Products

Test Procedures

- ANSI/SDI A250.3** Test Procedure & Acceptance Criteria for Factory Applied Finish Coatings for Steel Doors and Frames
- ANSI/SDI A250.4** Test Procedure & Acceptance Criteria for Physical Endurance for Steel Doors, Frames and Frame Anchors
- ANSI/SDI A250.10** Test Procedure & Acceptance Criteria for Prime Painted Steel Surfaces for Steel Doors and Frames
- ANSI/SDI A250.13** Testing and Rating of Severe Windstorm Resistant Components for Swinging Door Assemblies for Protection of Building Envelopes (Not applicable for FEMA 320/361 or ICC-500 Shelters)
- SDI-113** Standard Practice for Determining the Steady-State Thermal Transmittance of Steel Door and Frame Assemblies
- SDI-131** Accelerated Physical Endurance Test Procedure for Steel Doors

Construction Details

- ANSI/SDI A250.11** Recommended Erection Instructions for Steel Frames
- SDI-110** Standard Steel Doors & Frames for Modular Masonry Construction
- SDI-111** Recommended Details for Standard Steel Doors, Frames, Accessories and Related Components
- SDI-122** Installation Troubleshooting Guide for Standard Steel Doors & Frames

Miscellaneous Documents

- SDI-112** Zinc-Coated (Galvanized/Galvannealed) Standard Steel Doors and Frames
- SDI-117** Manufacturing Tolerances for Standard Steel Doors and Frames
- SDI-124** Maintenance of Standard Steel Doors & Frames
- SDI-127** Industry Alert Series (A-L)
- SDI-130** Electronic Hinge Preparations
- SDI-134** Glossary of Terms for Hollow Metal Doors and Frames
- SDI-135** Guidelines to Measure for Replacement Doors in Existing Frame Openings

MEMBERS OF THE STEEL DOOR INSTITUTE

CECO

AN ASSA ABLOY DOOR GROUP COMPANY
9159 Telecom Drive
Milan, TN 38358-3425
(731) 686-8345
www.cecodoor.com

CURRIES

AN ASSA ABLOY DOOR GROUP COMPANY
1502 12th Street, P.O. Box 1648
Mason City, IA 50402-1648
(641) 423-1334
www.curries.com

DEANSTEEL MANUFACTURING CO.

931 S. Flores Street
San Antonio, TX 78204-1406
(210) 226-8271
www.deansteel.com

DE LA FONTAINE INDUSTRIES, INC.

3 Normac Road
Woburn, MA 01801
(781) 932-8663
www.delafontaine.com

DCI

7980 Redwood Avenue
Fontana, CA 92336-1638
(909) 770-5700
www.dcihollowmetal.com

HOLLOW METAL XPRESS (HMX)

3440 Stanwood Boulevard
Huntsville, AL 35811-9021
(256) 851-6670
www.HMXpress.com

MESKER DOOR

3440 Stanwood Boulevard
Huntsville, AL 35811-9021
(256) 851-6670
www.meskerdoor.com

MPI

319 North Hills Road
Corbin, KY 40701
(606) 523-0173
www.metalproductsinc.com

PIONEER INDUSTRIES, INC.

AN ASSA ABLOY DOOR GROUP COMPANY
111 Kero Road
Carlstadt, NJ 07072
(201) 933-1900
www.pioneerindustries.com

PREMIER STEEL DOORS & FRAMES

2840 Sterlington Road
Monroe, LA 71203
(318) 361-0796
www.trustpremier.com

REPUBLIC DOORS & FRAMES

155 Republic Drive
McKenzie, TN 38201-0580
(731) 352-3383
www.republicdoor.com

STEELCRAFT

9017 Blue Ash Road
Cincinnati, OH 45242
(513) 745-6400
www.steelcraft.com

STILES

AN ASSA ABLOY DOOR GROUP COMPANY
1885 Kinser Road
Ceres, CA 95307
(209) 538-3667
www.stilesdoors.com



Standards As Tough As Steel.™

8/16/2023

STEEL DOOR INSTITUTE

30200 DETROIT ROAD • CLEVELAND, OHIO 44145
440.899.0010 • www.steeldoor.org